

WC940205

FINCHLEY STAINLESS STEEL DOUBLE DOOR CABINET



ILLUSTRATED

WC94205 FINCHLEY STAINLESS STEEL
DOUBLE DOOR CABINET

CONFIGURATIONS

N/A

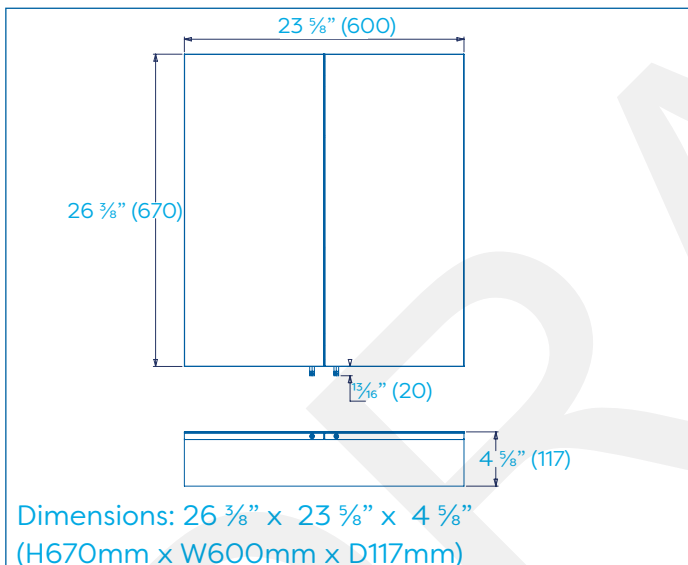

MATERIAL

Carcass: Grade 201 Stainless Steel and MDF
Door Front: Grade 201 Mild Steel, MDF, mirror
glass

Pin Handle: Chrome plated zinc

Shelf Material: Tampered Glass

COLOUR/FINISH

External: Stainless Steel mirror finish

Internal: White

WEIGHT

30lb (14kg)

PACKAGING

White box with colour label

FREQUENTLY USED APPLICATIONS

Residential

Hotels

FEATURES

Two adjustable shelves.

Reversible door with dual pin handle holes.

Easy to install Help 'n' Hang system.

100 ° degree hinges.

CARE AND MAINTENANCE

Clean surfaces with a damp cloth and wipe
dry using a soft cloth.

Do not use chemical or abrasive cleaners as
these may damage the surface finish.

GUARANTEE

Consumer Statutory Rights Apply

Tel: +44 (0) 1264 365881
Fax: +44 (0) 1264 356437
Email: info@croydex.co.uk
Web: www.croydex.com

Printed material, designs and packaging are
protected by copyright and design right.

Date Created:10/01/22 | REV 001